

# Telemetry Running Line Monitor

## RLM-3.0-T

The DLM Telemetry Running Line Monitor measures the tension on a rope passing through its three wheels. Typically used in cable laying and winch operations to measure and record line tension. The robust and wireless design has become an industry standard.

Product available in the following sizes: 15T, 60T, and 200T.



### Dimensional Data

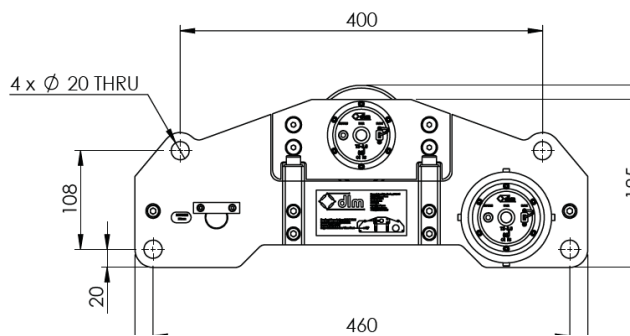

### Available Models

Part Number	Description	Wheel Sizes
0001-1468	Tension, Speed & Distance	8mm to 36mm
0001-1469	Tension Only	8mm to 36mm
0001-1404	Tension, Speed & Distance	26mm to 60mm
0001-1462	Tension Only	26mm to 60mm
0001-1405	Tension, Speed & Distance	38mm to 76mm
0001-1463	Tension Only	38mm to 76mm

### Accessories Table

Part Number	Description
0001-1452	Tethering Arm
0001-1462	Tethering Arm
0001-1450	Tethering Arm

### Specification

Frame Construction:	CNC machined side plates fixed together using high tensile stainless steel bolts and supporting spacers. No welded joints. Dual frame construction (upper and lower) for easy rigging and rope insertion. O-ring sealed encoder protection casing. Sealed roller bearings used on all wheels.
Frame Finish:	Galvanised prior to painting. Colour to suit customer requirements (orange and black as standard) Painted with marine grade paint.
Wheel Material:	EN24T alloy steel (Hardened to 40 Rockwell upon request).
Axles and Shear Pin Material:	17-4PH H1150 + 1150 stainless steel.
Shear Pin Load Cell Axle:	Suitable for line tensions up to 15t, 60t, and 200t (depending on model size).
Wireless:	The RLM transmits to one or more TW-3.0 display product using the licence free 2.4GHz frequency.
Load Cell:	The load cell wirelessly transmits the load readings from an internal transmitter to the display. The transmitter is powered by a 3.7VDC rechargeable battery.
Encoder:	Mounted inside O-ring sealed Encoder casing bolted to frame. Push-Pull quadrature output powered by an 3.7VDC rechargeable battery.
RLM Mounting:	4 machined eyes located on each side plate for easy rigging to spooling gear, or for use as lifting points. Machined stainless steel spacers double as lifting or carrying points.
Optional Extras:	Fleeting gear, Mounting posts, Mounting brackets.
Equipment Needed:	TW-3.0 Handheld Display or TW-3.0 USB Receiver and TW-3.0 RLM Display Software.
Available RLM Sizes:	15T, 60t, and 200t.

### Features:

- 800m wireless range
- Compatible with TW-3.0 products
- Fully sealed design to IP67
- Robust design suitable for harsh environments
- Integral speed and distance measurement as well as tension
- Easy to rig without the need to remove sheaves from axles
- Lifting and securing points
- Optional mounting fixtures

### Applications:

- Winch load monitoring
- Towing and salvage
- PLGR
- Cable laying