

Sandpoint Grapnel

The Sandpoint Grapnel is manufactured from high strength structured steel. The sizes normally used are 115kgs, 180kgs and 250kgs and this will depend on penetration requirements.

They are ideal for use on sandy or easily disturbed seabeds where little resistance will be experienced, and are particularly good where the cable has become self-buried to a small degree. They can also be added at the rear of the grapnel train for extra weight and penetration.

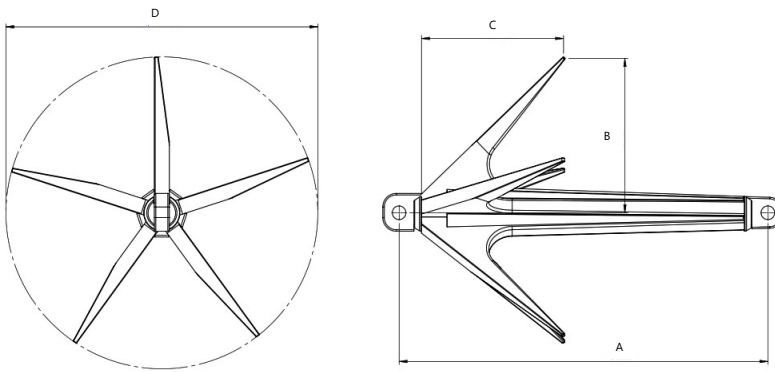

Features:

- Manufactured from high strength structural steel
- Integrated single piece prongs for increased strength
- Flux core welded for increased strength
- Integrated tow points
- Painted in marine friendly RAL2000 paint

Applications:

- PLGR (Pre Lay Grapnel Run)
- Designed for sandy seabed environments
- Recovering or clearing self buried cable
- Maintenance of cable systems
- Used in conjunction with Rennie and Gifford

Dimensions

Part Number	Description	A	B	C	D	WLL	Proof Load
0001-1183	115kg	950mm	385mm	330mm	782mm	7.5t	15t
0001-1184	180kg	1220mm	510mm	470mm	1032mm	7.5t	15t
0001-1166	250kg	1550mm	560mm	550mm	1132mm	7.5t	15t

Spares and Accessories Table

Part Number	Description
0050-0692	12t Shackle

*Not supplied with shackles